

This drawing contains confidential information and is the property of Takasago, without whose permission it may not be copied, shown or handed to a third party or otherwise used and it is to be returned promptly upon request to the design owner, who is responsible for the drawing.
 本图纸所包含的机密信息属于高砂电气的财产，未经许可不得复制或、不得向第三方展示或转交、或者另作他用；在该图纸的负责部门---设计单位的要求下，本图纸须立即返回。

Items shown in this drawing must not contain substances that are banned according to RoHS Directive (Lead, Cadmium, Mercury, hexavalent Chromium, PBB and PBDE), or substances classified as "Banned" or "Restricted" according to the Takasago Restricted Materials List.
 该图所示的各个部件必须不含欧盟RoHS指令所规定禁止的物质（铅、镉、汞、六价铬、多溴联苯和多溴二苯醚）或高砂电气限制材料清单中被列为“禁用”或“限用”的物质。

GENERAL TOLERANCE 未注公差：
 1) ANGLE 角度公差：±1°
 2) LENGTH AND DIA. 长度及直径(半径)公差：
 INJECTED PART 注塑件: GB/T 14486
 MACHINED PART 机加工件: ISO 2768-mK
 CRITICAL DIMENSION 关键尺寸

FOR REFERENCE ONLY

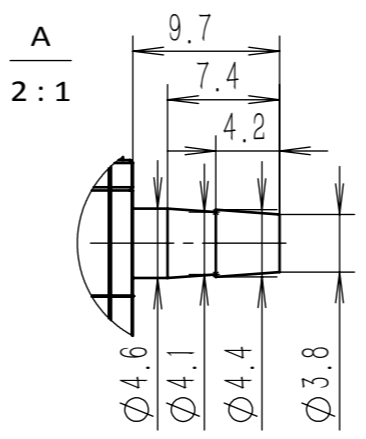
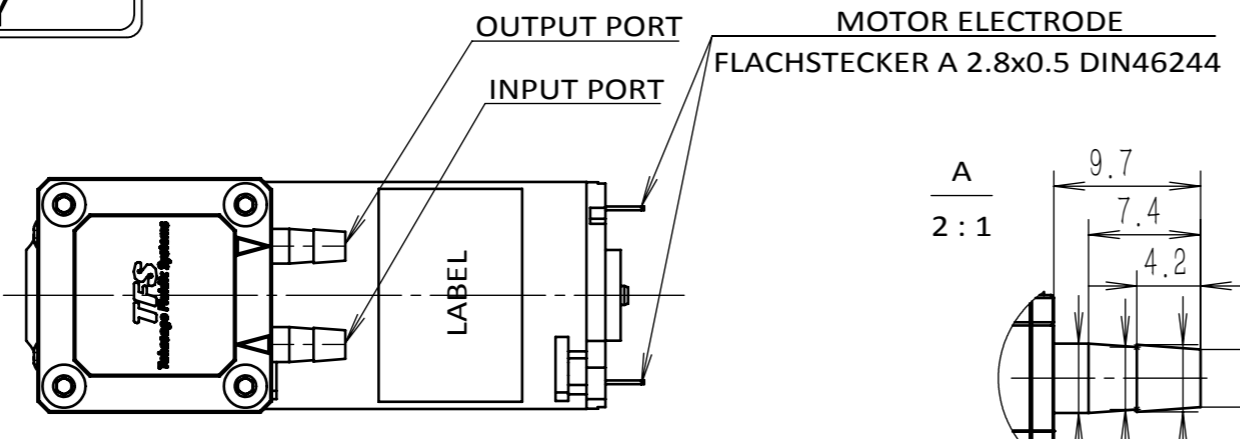

DIAPHRAGM LIQUID PUMP

- MODEL NUMBER : DAP-500P-N1E
- MAXIMUM PUMPED VOLUME : 500 mL/min
- PRESSURE ADJUSTABLE RANGE : -60kPa ~ +100kPa
- PORT CONNECTION : HOSE BARBS
- FLUID MEDIA : LIQUID CHEMICALLY COMPATIBLE WITH MATERIALS BELOW
- MEDIA TEMPERATURE : 5°C ~ 40°C
- AMBIENT TEMPERATURE : 5°C ~ 40°C
- RATED VOLTAGE : 12 VDC / 24 VDC
- DUTY CYCLE : CONTINUOUS
- INSULATION CLASS : CLASS E
- POWER CONSUMPTION : 8 W

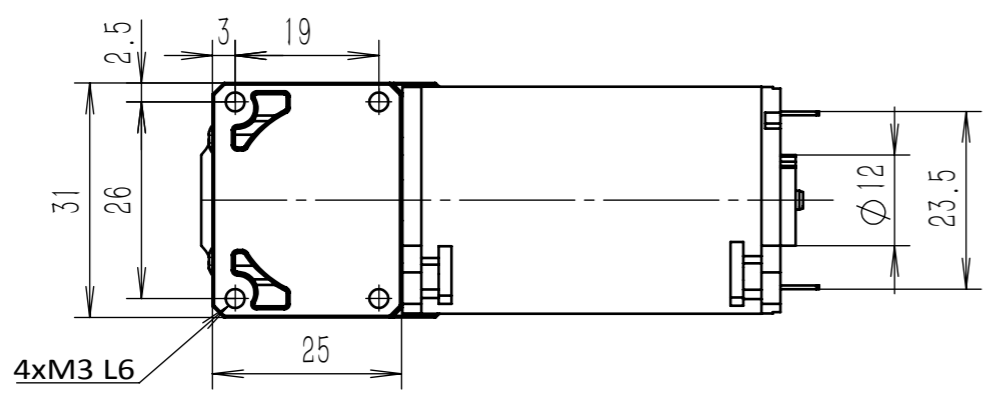
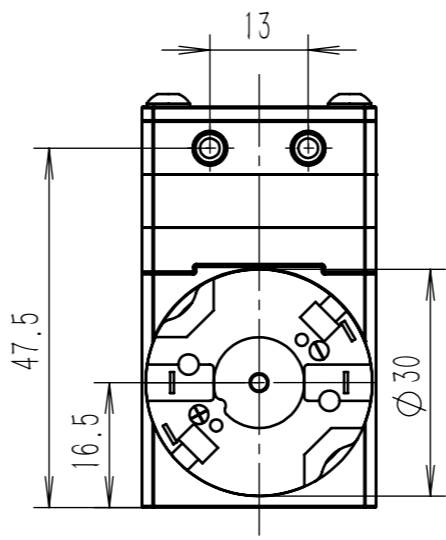
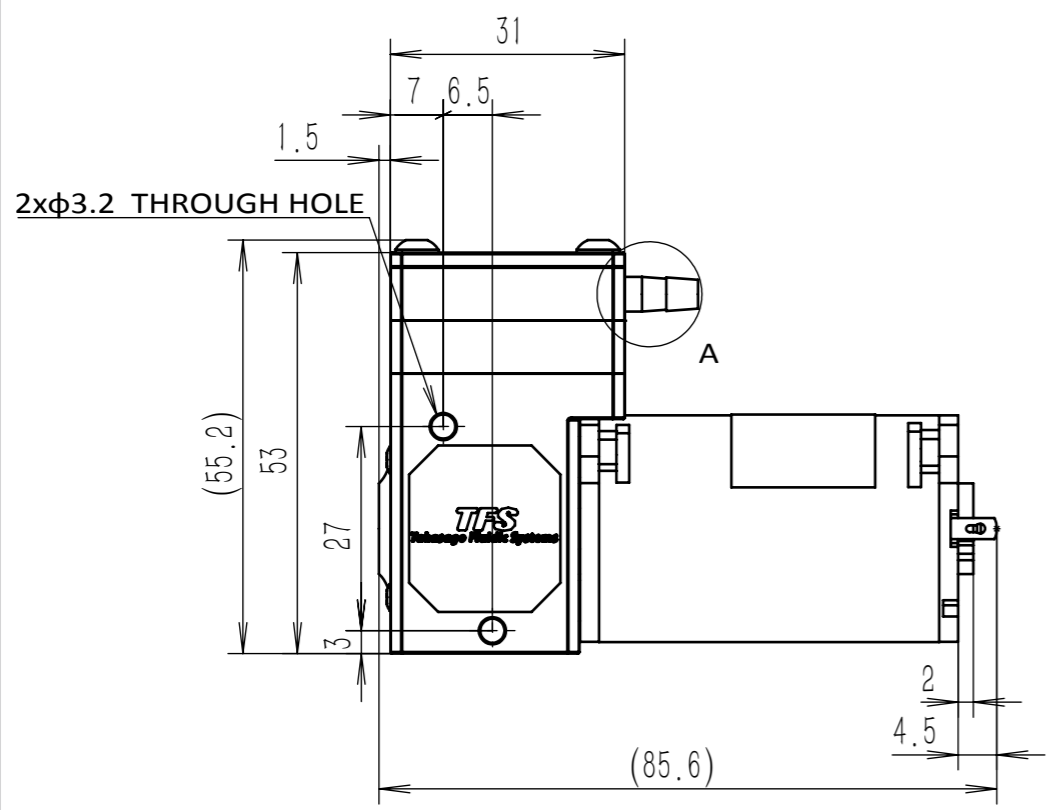

WETTED MATERIALS 接液部材质

4	DIAPHRAGM 隔膜	EPDM	1	
3	LOWER PLATE 下盖板	PP+20%GF	1	
2	CHECK VALVES 单向阀	EPDM	2	
1	MIDDLE PLATE 中盖板	PP+20%GF	1	

ITEM 编号	PART NAME 部品名	MATERIAL 材料	QUANTITY 数量	MARK 备注
---------	---------------	-------------	-------------	---------

MATERIAL 材料	-	APPROVED BY 批准	苏州高砂 2020.04.23	DATE 日期		THIRD ANGLE PROJECTION
COLOUR 颜色	-	CHECKED BY 校对	何振良	DATE 日期		
TREATMENT 处理方式	-	DRAWN BY 设计	郑玉林	DATE 日期	2019.12.3	

	DRW. NUMBER 图号	S16001-F00-00-M00	SCALE 比例	1:1	SIZE 图纸	A3
	MODEL NUMBER 型式	DAP-500P-N1E				
	REV. 版本	00	SHEET 页	1/1		